

SOLAR MODEL CAR

Single Cell Car Assembly Guide

1. Inventory of components

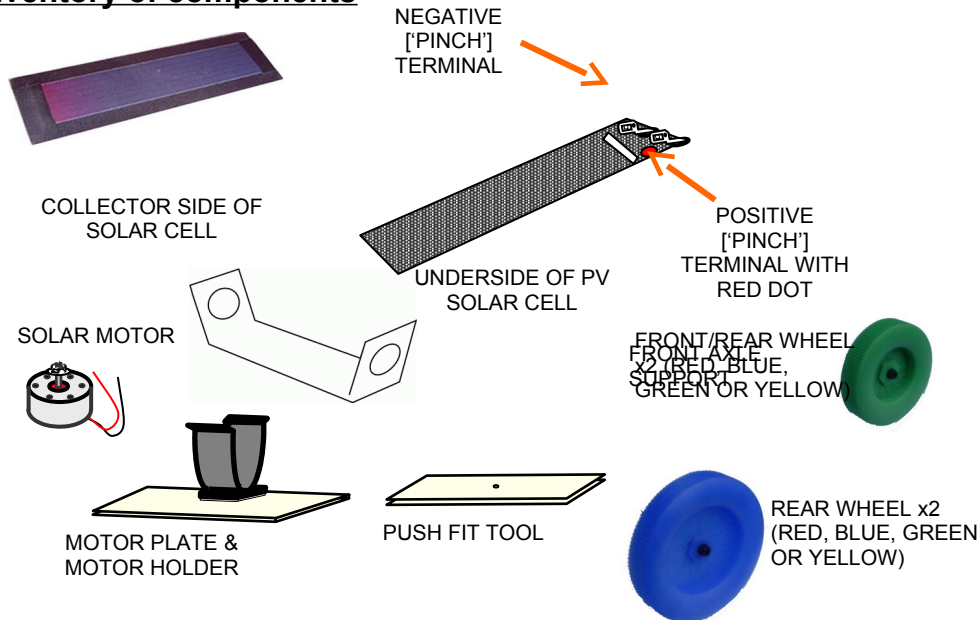

Check that you have all these parts:

- 1 solar cell
- 2 small wheels
- 2 large wheels
- 1 axle shaft
- 1 front axle support
- motor plate & motor holder
- push fit tool

1.1 Identify the three speed gearbox components

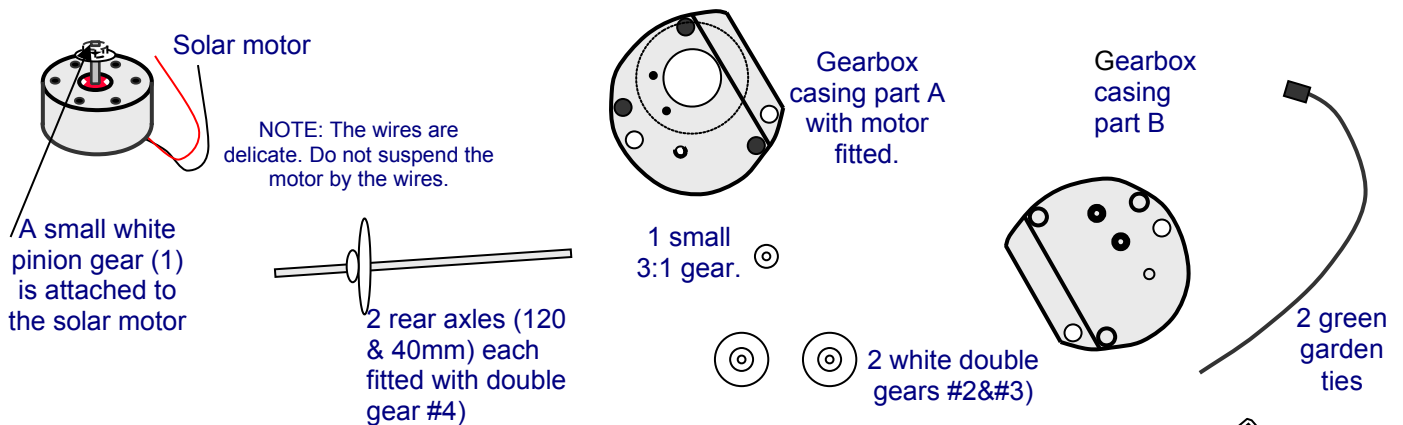

2. Chassis

The PV solar cell is the chassis of the car. Attach two (SPIKY) Velcro pads to the underside of cell (**Fig. 1**). The front pad is **centred and 8mm from the front edge** and the back pad sits between the two pinch terminals, **14 mm from the back edge**.

Figure 1

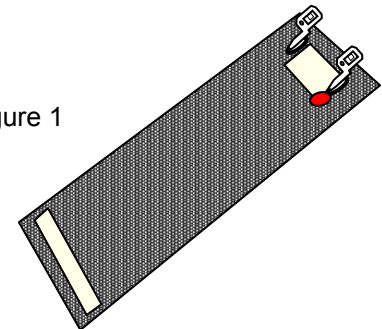

3. Front wheel assembly (work in pairs)

Safety: The steel axle shafts are thin, and could potentially pierce the skin. Do not push the wheels using the bare palm of your hand. **Always use the push fit tool, and push the wheel using both thumbs on the edges. When assembling the wheels, work in pairs.**

3.1 Attach the small fuzzy Velcro strip to the front axle support as shown in figure 2. Please note this may have already been done for you.

3.2 From a standing position, place one end of the axle shaft without the white gear into the push fit tool (Fig. 3.)

3.3 From a standing position, one person holds the axle shaft, the other person takes the small wheel, finds the hole in the reducer and places the hole in the reducer over the top end of the shaft.

3.4 From a standing position, place thumbs on the edges of the wheel and **gently** push the wheel onto the axle shaft $\frac{3}{4}$ into the reducer.

3.5 Thread axle shaft through the front axle holder (Fig. 4.)

3.6 Place the attached wheel onto a 5p coin so the axle shaft doesn't push through.

3.7 Follow step 3.3 & 3.4 above to attach the other wheel.

3.8 Attach front wheel assembly to single Velcro pad (Fig. 4.) Ensure that the axle is parallel to the front edge.

4. Rear Motor/Wheel Assembly

4.1 One furry Velcro pad is attached to motor holder plate.

4.2 Remove backing paper from adhesive strip on the black motor holder clip and attach it to centre of motor holder plate (Fig. 4B) on opposite side to Velcro pad. Make sure **motor holder is straight (perpendicular to long edge of the plate) and centred.**

4.3 Attach motor plate holder to rear Velcro pad.

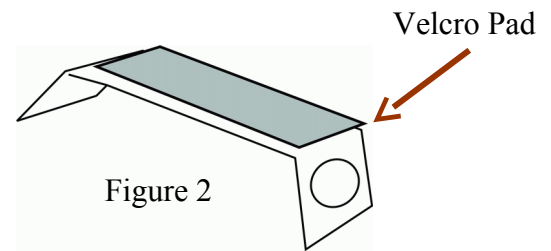

Figure 2

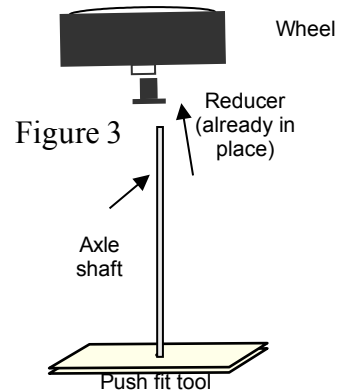
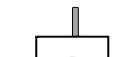

Figure 3



Front wheel axle support



Figure 4A

5p coin

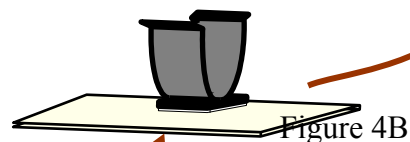
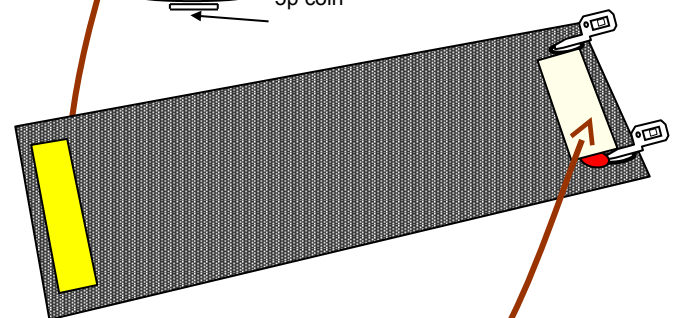

Figure 4B

Velcro pads on opposite side

5. Assembling of 9:1 transmission gear

5.1 Notice that the motor is fitted into the casing (Part A) with a white pinion gear (1) attached near the top of motor shaft (Fig. 5.)

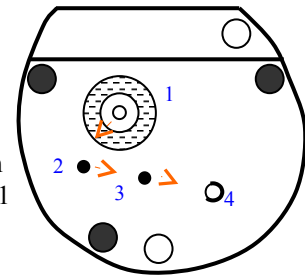

Figure 5: casing with motor + pinion gear 1

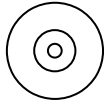
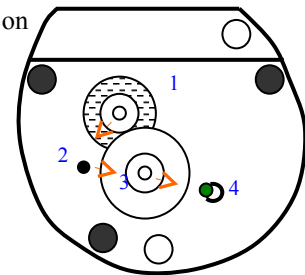

Figure 6: double gear

5.2 Feel the white toothed double gear (Fig. 6) between your thumb and forefinger. One side is smooth and the other side will feel rough as it has an 8-toothed gear.

5.3 Slide the double gear (3) flat side down onto the MIDDLE spindle. The smaller 8-toothed gear will be at the top of the spindle. (Fig. 7.) [Note: do not insert a gear on spindle (2)]

Figure 7: gear 3 on middle spindle



5.4 Thread longer end of 120mm/40mm/70mm axle shaft, with smooth side of gear down, through hole (4) just to right of gear 3 so it meshes with gear (3). (Fig. 8)

Figure 8: gears 1, 3 and 4 in place.

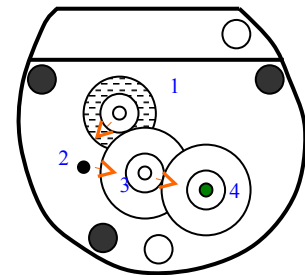

5.5 Test gears by turning axle shaft and watch gears meshing together. If necessary make fine adjustment to position of gear (1) on motor shaft so gears runs smoothly.

5.6 Thread the axle shaft through the hole in the casing part B. Snap casing B together with part A. (Figs 10/11). Use pressure when snapping A & B together. You may need assistance.

5.7 With repeated use, parts A&B might not snap together tightly. If this happens (at first casing should fit tightly), use green garden ties to secure motor. Thread ties through two outer holes to fix casing parts together. Trim ends of ties. Ensure cut ends do not touch wheels.

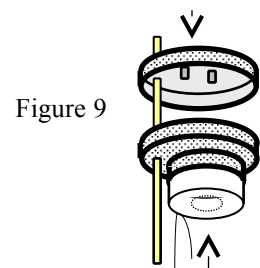

Figure 9

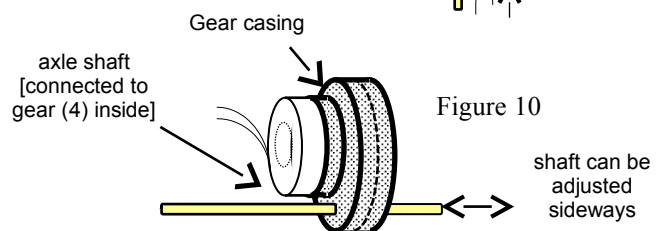

Figure 10

6. Attaching gearbox and wheels (work in pairs)

6.1 Place one end of the shaft into the push-fit tool. (Fig. 13.)

6.2 Firmly hold the motor casing between your thumb and forefinger.

6.3 Use same method as steps 3.2 & 3.3

to attach large wheels to the axle shaft. When using the 40mm axle use small wheels.

6.4 Remove the axle shaft from the push fit tool and place the attached wheel onto a 5p coin so the axle shaft doesn't push through.

6.5 Attach the other wheel following steps 3.3 & 3.4.

6.6 Push silver motor (not any part of gearbox casing) into motor mount **with motor casing on your right (Figs 12/14)** and with wires extending above the mount and with flat edge of gearbox next to motor plate. **The rear axle should be parallel with the back edge of the PV solar cell.**

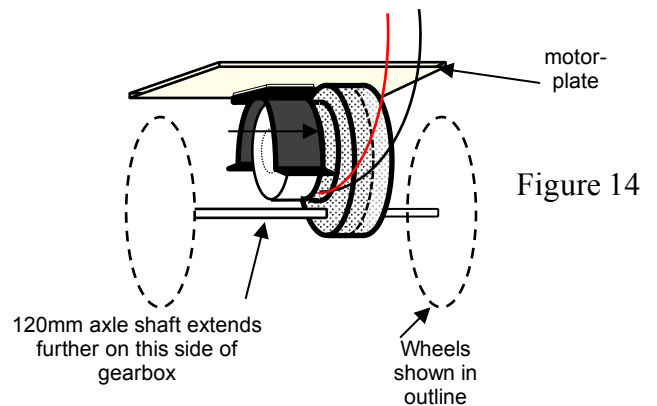
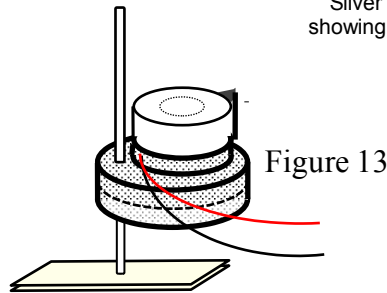
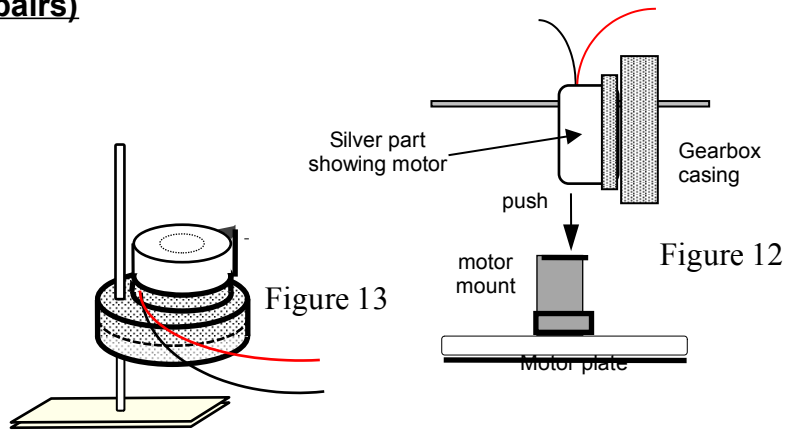

7. Attaching wires to the pinch terminals

7.1 Pinch the SILVER spring terminal (Fig 15) and a hole will pop out (Fig 16.)

SIDE VIEW

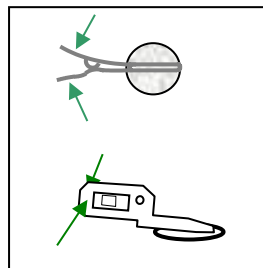
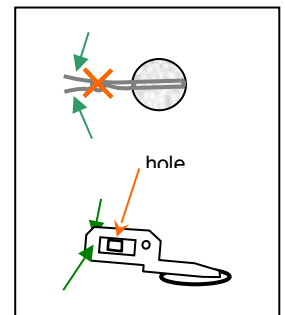

Figure 16



SIDE VIEW

7.2 Push gold motor plug straight down through hole (Fig 17)

7.3 Release pinch to grip plug.

7.4 Repeat with the other plug.

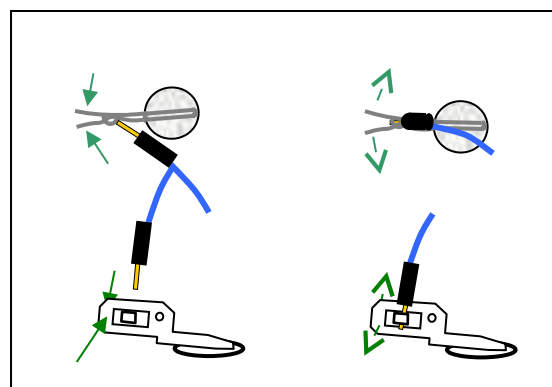

Figure 17

SIDE VIEW

Appendix A: Choosing different gear ratios

Transmission ratios:	Name:	Characteristics:	Solar Car Performance
27:1	1 st gear	Slowest axle-speed and the most torque (turning force).	The car will climb steeper gradients
9:1	2 nd gear	Medium axle-speed and medium torque.	A good 'all round' gear ratio.
3:1	3 rd gear	Fastest axle-speed and the least torque.	Under favourable conditions the car will go fastest in this gear.

A 1. Assembling of 27:1 transmission gear

A 1.1 Leave motor in casing and adjust position of pinion gear (1) halfway down the motor shaft (with your fingers or a small flat-bladed screwdriver).

Figure 18: casing with motor + pinion gear 1

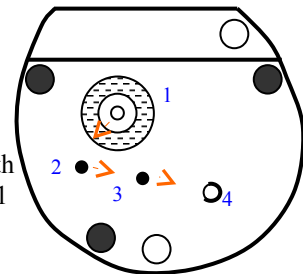

A 1.2 Feel the white toothed double gears (**Fig. 6**) between your thumb and forefinger. One side is smooth and the other side will feel rough as it has an 8-toothed gear.

Figure 19: gear 2 on spindle 2

A 1.3 Slide the double gear (2) **flat side down** onto spindle 2. (**Fig. 19.**)

A 1.4 Slide double gear (3) **flat side down** onto the middle spindle. (**Fig. 20.**)

Figure 20: gears 1, 2 and 3 in place.

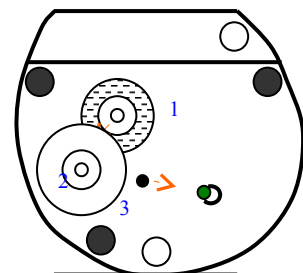

A 1.5 Thread longer end of 120mm/40mm/70mm axle shaft, with smooth side of gear down, through hole (4) just to **right** of gear 3 so it meshes with gear (3). (**Fig. 21**)

A 1.6 Test gears by turning axle shaft and watch gears meshing together. Gear 1 must mesh with gear 2, **but not with gear 3**. If necessary make fine adjustment to position of gear (1) on motor shaft so gears runs smoothly.

A 1.7 Continue from step 5.7-7.4.

Figure 21

: gears 1, 3 and 4 in place.

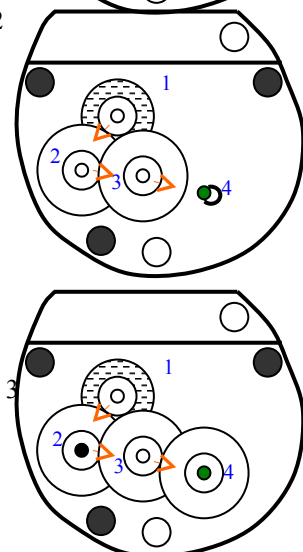

A 2. Assembling of 3:1 transmission gear

A 2.1 Leave motor in casing and adjust position of pinion gear (1) to **top of motor shaft** (with your fingers or a small flat-bladed screwdriver).

Figure 22: casing with motor + pinion gear 1

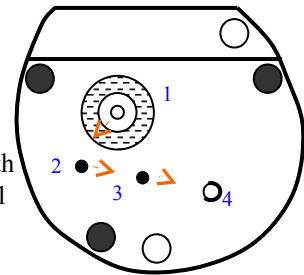

A 2.2 Feel the white toothed double gears (**Fig. 22**) between your thumb and forefinger. One side is smooth and the other side will feel rough as it has an 8-toothed gear.

Figure 23: gear 2 on spindle 2

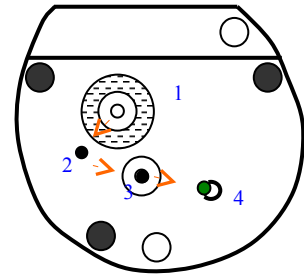

A 2.3 Slide small gear (3) **flat side down** onto the middle spindle. (**Fig. 23**)

A 2.4 Slide the double gear (2) **flat side up** onto spindle 2. (**Fig. 24**)

Figure 24: gears 1, 2 and 3 in place.

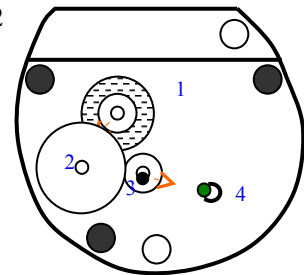

A 2.5 Thread longer end of axle shaft, with smooth side of gear down, through hole (4) just to **right** of gear 3 so it meshes with gear (3). (**Fig. 25**)

A 2.6 Test gears by turning axle shaft and watch gears meshing together. Gear 1 must mesh with gear 2, **but not with gear 3**. If necessary make fine adjustment to position of gear (1) on motor shaft so gears runs smoothly.

Figure 25

: gears 1, 3 and 4 in place.

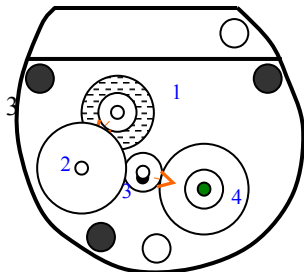

A 2.7 Continue from step 5.7-7.4.

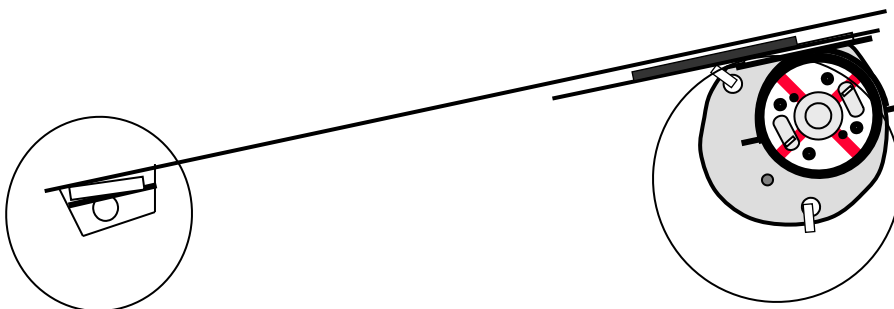

Car body shell

Make a car body shell by following the instructions in the Body Construction Guide. The instructions and blank body shell templates can be downloaded using the password **bodyshop** in SPECIAL FILES AND DOWNLOADS on front page of website.

Appendix B: Problem Solving

Problem	Check Items ⇒ Solution
Gearbox does not run smoothly	<p>bent axle shaft ⇒ replace shaft</p> <p>gear teeth clogged ⇒ remove obstructions from within gear teeth</p> <p>ratio 3:1</p> <p>pinion gear (1) & double gear (2) not meshing smoothly ⇒ adjust position of pinion gear (1) on motor shaft to correct height for gear ratio 3:1</p> <p>double gear (2) wrong way round ⇒ insert double gear (2) with 8 tooth gear towards bottom of spindle</p> <p>single gear (3) wrong way round ⇒ insert with flat side towards bottom of spindle</p> <p>ratio 9:1</p> <p>pinion gear (1) & double gear (3) not meshing smoothly ⇒ adjust position of pinion gear (1) on motor shaft to correct height for gear ratio 9:1</p> <p>double gear (2) fitted in error ⇒ remove large gear (2), it is not used in ratio 9:1</p> <p>ratio 27:1</p> <p>pinion gear (1) & double gear (2) not meshing smoothly ⇒ adjust position of pinion gear (1) on motor shaft to correct height for gear ratio 27:1</p> <p>pinion gear (1) may be meshing with gears (2) and (3) - this jams the gearbox ⇒ adjust position of gear (1) to mesh with gear (2) only.</p>
Car goes backwards	polarity reversed ⇒ reverse terminal connections or reverse position of motor
Wheels do not turn or car runs slowly	<p>insufficient light intensity at solar cell ⇒ read 'How much light...' above</p> <p>gear ratio not ideal for conditions ⇒ change gear ratio higher or lower ⇒ alter diameter of wheels larger or smaller</p> <p>high electrical resistance ⇒ check soundness of connections between motor plugs and solar terminals ⇒ check for broken motor wires</p> <p>rolling resistance too high ⇒ try car on a smooth and level surface ⇒ change ratio</p> <p>bent axle at either end ⇒ remove axle and check it by rolling on a smooth surface, replace if not straight</p> <p>axles not parallel ⇒ make adjustments with reference to assembly guide criteria</p> <p>axle tight in bearing at either end ⇒ pull wheels along axle and away from bearing to leave some free-play (1-2mm)</p> <p>axle fitted tightly in hole of casing ⇒ move axle in hole to enlarge hole</p>

How much light does the solar (photovoltaic*) cell need? Getting the best from your photovoltaic (solar electric) cell.

A bright light source has more energy!

A solar cell converts light energy into electrical energy. If the intensity of light falling on the cell goes down, the electrical power output falls also. The electrical current output from the cell is very sensitive to light intensity. Maximum power output is produced when the incident light beam (i.e. when it is pointed at the sun) is perpendicular (90 degrees) to the cell surface.

Solar power is best obtained from the sun!

The UNI-SOLAR solar cell is designed for daylight or natural wavelengths of light (including diffuse light i.e. light scattered by cloud cover), not wavelengths from artificial light sources. However, soft white fluorescent lighting works best with the UNI-SOLAR cell.

The power output of the solar cell will be diminished in inverse proportion to the square of the separation distance from the light source to the surface of the solar cell. In other words, the motor in our solar car/boat kit will work by putting the solar cell directly under the artificial light source but if you double the distance you will only get 1/4 of the light intensity and the motor will probably stop working.

Dull days!

Diffuse sunlight from a cloudy sky can provide enough energy for the solar motor of the car/boat or mini-water pump to spin – but not always to run these devices. For the car, it will depend on gear ratio, wheel surface and size, the surface that you run the car on, time of day and season.

Solar radiation is very variable – from place to place, from time to time and from season to season. For example, in the UK during the winter months, when the sun is ‘lower’ in the sky, diffuse sunlight may not run the car or boat during the early morning hours but by mid-day the car and boat will work.

OK so there is no sun at all today...

A 100W standard tungsten filament bulb held closely to (but not touching) the collector side of the solar cell will spin the motor. However, it is not the way to show how solar energy works. Remember that about 95 of the 100watts going into the lamp is given off as heat not light! Beware of burns to hands and melting plastics. A halogen security lamp (500w), OHP projector lamp or high intensity spotlight will power the car, but again the heat build-up is a safety issue. **Low energy lamps will not power the motor.**

Explaining natural energy use

Natural energy sources such as the sun, the wind and waves vary in intensity all the time. Harnessing and storing this energy is an important aspect of renewable energy, which is well illustrated by this solar electric model car kit.

Please try not to demonstrate solar power in very poor light conditions, unless you already know that the electrical device can work under those conditions. For example, a 12V piezo buzzer will work under poor light conditions with the solar cell in this kit.

(* The term ‘*photovoltaic*’ is derived by combining the Greek word for light, *photos*, with *volt*, the name of the unit of electromotive force.)